

Name: _____

Skill Sheet 20.1

Parallel and Series Circuits

There are two major types of electrical circuits: series and parallel. In a series circuit, current follows only one path. In a parallel circuit, the current has two or more possible paths. In both types of circuits, the current travels from the positive end of the battery toward the negative end. The amount of energy used by a circuit (series or parallel) must equal the energy supplied by the battery. In this way, electrical circuits follow the law of conservation of energy. Understanding these facts will help you solve problems that deal with series and parallel circuits.

1. Solving series circuit problems

Now it is time for you to test your knowledge of series and parallel circuits by answering the questions below. You will have to use Ohm's law to solve many of the problems, so remember:

$$\text{Current (amps)} = \frac{\text{Voltage (volts)}}{\text{Resistance (ohms)}}$$

Some questions ask you to calculate a *voltage drop*. We often say that each resistor creates a separate voltage drop. As current flows along a series circuit, each resistor uses up some energy. As a result, the voltage gets lower after each resistor. If you know the current in the circuit and the resistance of a particular resistor, you can calculate the voltage drop using Ohm's law.

$$\text{Voltage drop (volts)} = \text{Current (amps)} \times \text{Resistance of one resistor (ohms)}$$

1. Use the series circuit pictured at right to answer questions a-e below.

a. What is the total voltage of the circuit?

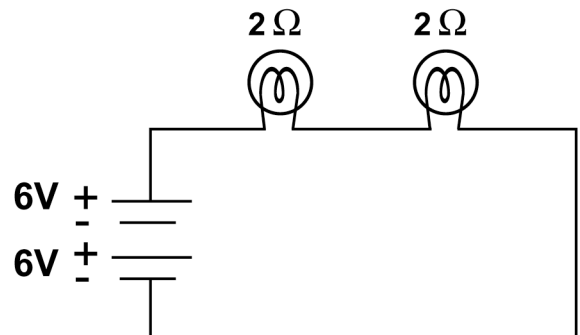

b. What is the total resistance of the circuit?

c. What is the current flowing through the circuit?

d. What is the voltage drop across each light bulb? (Remember that voltage drop is calculated by multiplying current in the circuit by the resistance of a particular resistor: $V = IR$.)

e. Draw the path of the current flow on the diagram.

2. Use the series circuit pictured at right to answer questions a-c below. Consider each resistor equal to all others.
- What is the resistance of each resistor?

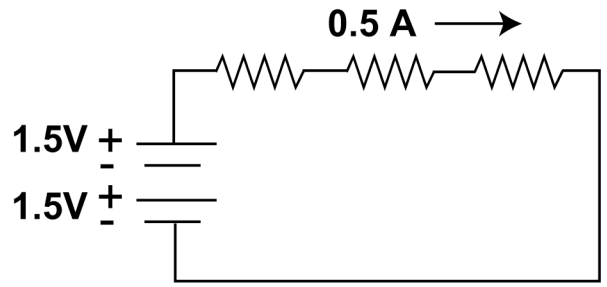

- What is the voltage drop across each resistor?

- On the diagram, show the amount of voltage in the circuit before and after each resistor.

3. Use the series circuit pictured at right to answer questions a-d below.

- What is the resistance of the circuit?

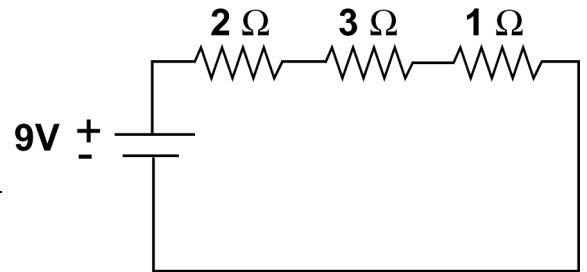

- What is the current flowing through the circuit?

- What is the voltage drop across each resistor?

- On the diagram, show the amount of voltage in the circuit before and after each resistor.

2. Solving parallel circuit problems

A parallel circuit has at least one point where the circuit divides, creating more than one path for current. Each path is called a branch. The current through a branch is called branch current. Remember that if current flows into a branch in a circuit, the same amount of current must flow out again. This rule is known as **Kirchhoff's current law**.

For example, suppose you have three light bulbs connected in parallel, and each has a current of 1 amp. The battery must supply 3 amps since each bulb draws 1 amp. Before the first branch point, 3 amps are flowing. One amp goes down the first branch to the first bulb, and 2 amps flow on to supply the next two bulbs.

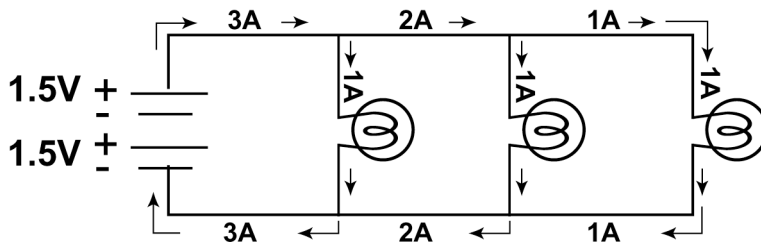

1. Use the parallel circuit pictured at right to answer questions a-c below.

a. What is the total voltage for the circuit?

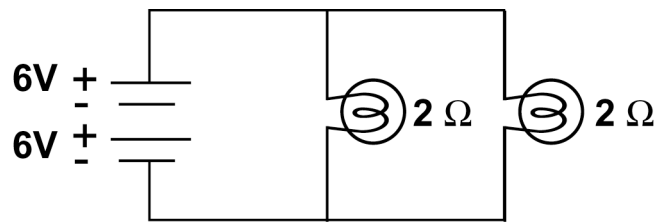

b. What is the current flow through each branch?

c. What is the voltage in each branch?

2. Compare the circuits in Part 1, question 1 and Part 2, question 1. What is the current flow through each bulb in the series circuit compared with the current flow through each bulb in the parallel circuit? Which bulbs would be brighter? Explain your reasoning.

3. Use the parallel circuit pictured at right to answer questions a-d below.

a. What is the voltage through each branch?

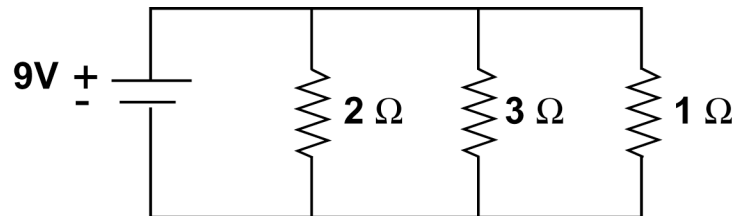

b. What is the current flow through each branch?

c. What is the power of each resistor? (Remember that power is current multiplied by voltage.)

d. What is the relationship between current and power?